









Produktdatenblatt

Produktname	Kurze Hydraulikspindel. Zum Abziehen von besonders festsitzenden Lagern, Zahnrädern, Scheiben etc.
Produktnummer	800
Baureihe	800
EAN	4021176034343



Technische Attribute

Attributname	Attributwert
 Gewinde	W 1.1/2"-16(55°;16Gang)
 Hub	10 mm (3/8 inch)
 Schlüsselweite	13 mm
<small>max.</small> Maximal zulässige Belastung	10.5 t (11.5 US t)
 <small>max.</small> max. Drehmoment	40 Nm
 Gewicht	1.5 kg
 <small>max.</small> max. Drehmoment	29.5 ft lb

Ersatzteil

Produktnummer	Produktname
800-ERS	Verschleißteilsatz
800-REP	Werkinstandsetzung
800017	Druckstück
610075	Spindel
ERS-Oil	Hydrauliköl in Dosierflasche

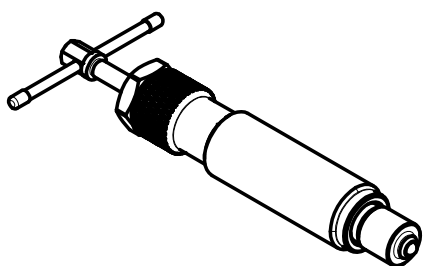
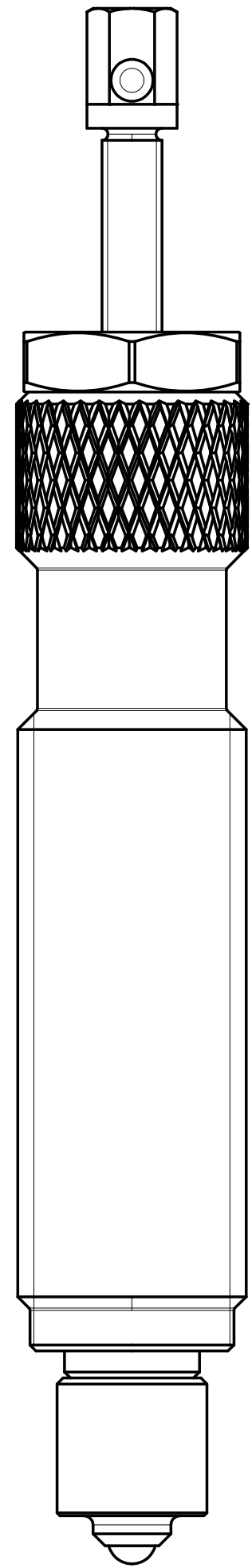
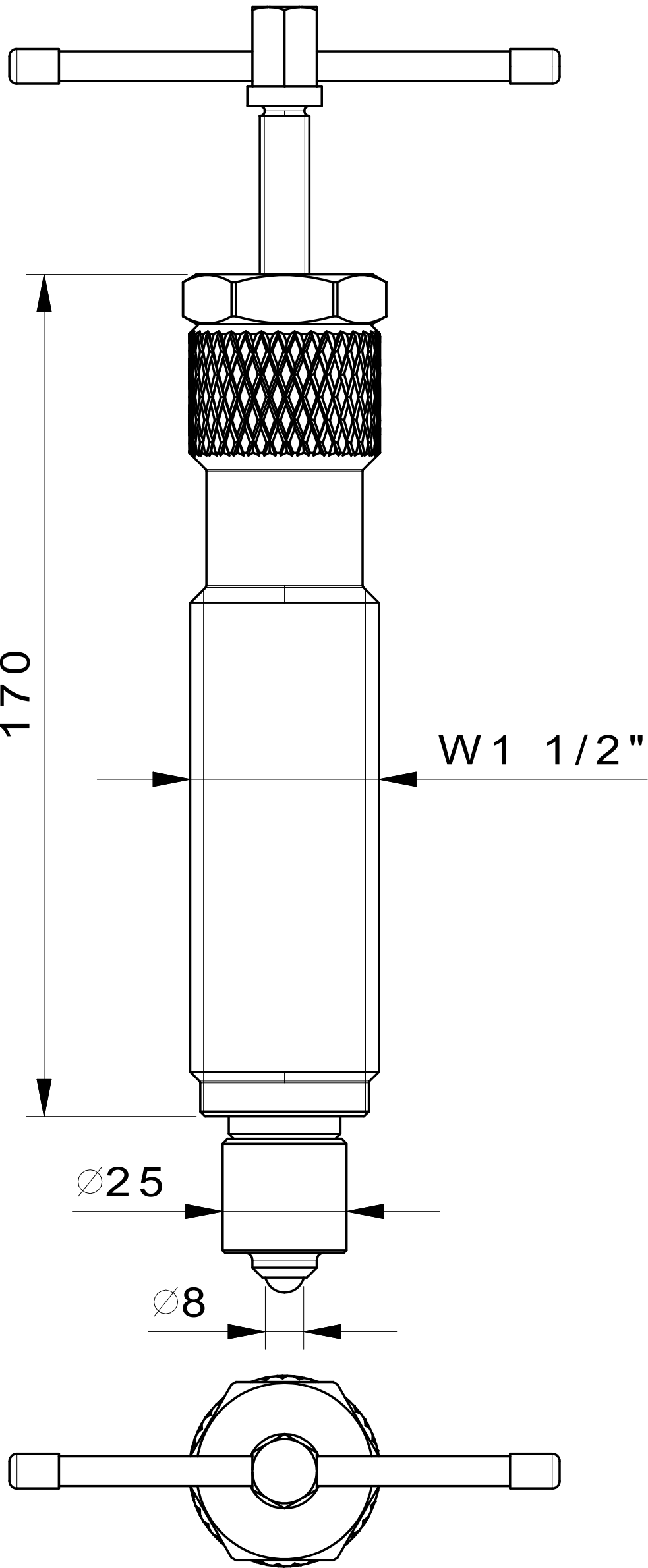

 Kleinbongartz & Kaiser oHG Werkzeugfabrik Hilden - Germany	Dokumentname: 800_Kurze Hydraulikspindel		Toleranz: DIN ISO 2768-m
	Dokumentbeschreibung: Baugruppe		Material: Vergütungsstahl/ heat treatable steel
Erstellt von: Breidenbach	Erstellungsdatum: 25/08/2017	Maßstab: 1:1	
Teilbeschreibung: Kurze Hydraulikspindel/ Short hydraulic spindle		Wärmebehandlung / Härte: vergüteter Stahl/ tempered steel	
		Oberflächenbehandlung:	
Artikelnummer / ZNR.: 800	Dokumentversion: -	Schutzvermerk ISO 16016 beachten	