

RECHTECK-PUMPENTRÄGER MIT DÄMPFUNGSFLANSCH DF-ZRP

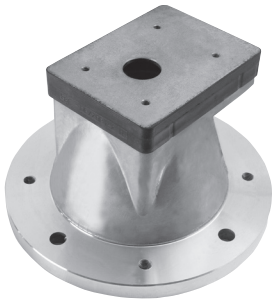

RECTANGULAR BELLHOUSINGS WITH DAMPING FLANGE DF-ZRP

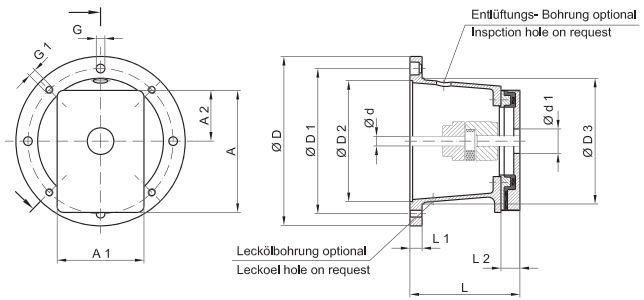

PRODUKTbeschreibung

- Keine metallische Verbindung
- Schallpegelreduzierung der Pumpen-/ Motoreinheit je nach Pumpenkonstruktion bis zu 5 dB (A) möglich
- Standardpumpenträger aus Aluminium
- Einsatz horizontal/vertikal möglich
- Beständigkeit: Mineralöl max. 80°C
- Unserem Auslegungsprogramm steht als kostenloser Download unter www.hbe-hydraulics.com zur Verfügung.

PRODUCT DESCRIPTION

- No metallic connection
- Reduction of noise level of the pump motor unit possible up to 5 dB (A) depending on pump construction
- Bellhousings made of aluminium
- Horizontal and vertical application possible
- Resistance: mineral oil 80°C max.
- Our selection software is available at www.hbe-hydraulics.com free of charge.

IEC-MOTOR BAUGROSSE / SIZE WELLE/NDE SHAFT (d x L)	KW/BEI n = 1500 min ⁻¹	BAUFORM FRAME	PUMPENTRÄGER UND DÄMPFUNGSFLANSCH BELLHOUSING AND DAMPING FLANGE	ELASTISCHE KUPPLUNG ELASTIC COUPLING	FUSSFLANSCH FOOT BRACKET	DICHTUNG GASKET	ABMESSUNGEN / DIMENSIONS mm												
							MOTORSEITE MOTOR SIDE						PUMPENSEITE PUMP SIDE						
							TYP / SIZE	TYP / SIZE	TYP / SIZE	TYP / SIZE	TYP / SIZE	TYP / SIZE	TYP / SIZE	TYP / SIZE	TYP / SIZE	TYP / SIZE	TYP / SIZE	TYP / SIZE	TYP / SIZE
71 (14 x 30)	0,25- 0,37	IMB 5 IMV 1	PRE 160/90 DFZRP/...	19/24	PTFL 160	D 160 GK	øD	øD ₁	øD ₂	øD ₃	L	L ₁	L ₂	G	G ₁	øA	øA ₁	øA ₂	d _{1min}
80 (19 x 40)	0,55- 0,75	IMB 14	PRE 160/90 DFZRP/...	19/24 24/30	PTFL 160	D 160 GK	160	130	110	110	90	13	20	9	M8	121	92	46	22
		IMB 5 IMV 1	PRE 200/100 DFZRP/... PRE 200/118 DFZRP/...		PTFL 200 PTFS 200	D 200 GK	200	165	130	145	100 118	16 15	20	11	M10	121	92	46	22
90 S+L (24 x 50)	1,1- 1,5	IMB 14	PRE 160/90 DFZRP/...	19/24 24/30	PTFL 160	D 160 GK	160	130	110	110	90	13	20	9	9	121	92	46	22
		IMB 5 IMV 1	PRE 200/100 DFZRP/... PRE 200/118 DFZRP/...		PTFL 200 PTFS 200	D 200 GK	200	165	130	145	100 118	16 15	20	11	M10	121	92	46	22
100 L 112 M (28 x 60)	2,2- 4	IMB 14	PRE 160/110 DFZRP/...	24/30	PTFL 160	D 160 GK	160	130	110	110	110	34	20	9	9	121	92	46	22
		IMB 5 IMV 1	PRE 250/114 DFZRP/...		PTFL 250 PTFS 250	D 250 GK	250	215	180	190	114	19	20	14	M12	121	92	46	22
132 S+M (38 x 80)	5,5- 7,5	IMB 5 IMV 1	PRE 300/153 DFZRP/...	28/38	PTFL 300 PTFS 300	D 300 GK	300	265	230	234	153	20	20	14	M12	121	92	46	22

Für größere Antriebleistungen von Motor-Baugrößen 160-280 siehe Maßblatt Rundpumpenträger mit Dämpfungsflansch

For higher driving power of motor size 160-280 please see dimension sheet round bellhousings with damping flange

BESTELLBEISPIEL: PUMPENTRÄGER MIT DÄMPFUNGSFLANSCH

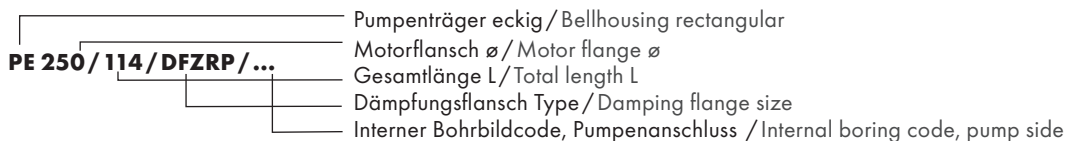

ORDERING CODE: BELLHOUSING WITH DAMPING FLANGE

BESTELLBEISPIEL: KUPPLUNG

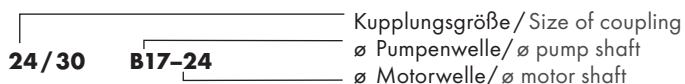

ORDERING CODE: COUPLING