

## STAREX® FLEXIBLE KUPPLUNGEN



### PRODUKTBESCHREIBUNG

- Doppelkardanische Zahnkupplung
- Anwendung im allgemeinen Maschinenbau / in der Hydraulik
- Wartungsfrei durch Werkstoffpaarung Kunststoff / Stahl
- Ausgleich von Wellenfluchtungsfehlern Axial - Radial - Winkel
- Axial steckbar - einfach Montage
- Lieferbar mit Fertigbohrung metrisch H7, Konus- und Zollbohrungen sowie Verzahnungen
- Basissortiment ab Lager lieferbar

### TECHNISCHE DATEN

TYP SIZE	VOR- BOHRUNG PREBORE	FERTIG- BOHRUNG <sup>1)</sup> FINISH BORE <sup>1)</sup>		ABMESSUNGEN / DIMENSIONS mm										VERLÄNGERTE NABEN EXTENDED HUBS max. mm L <sub>1</sub> + L <sub>2</sub>	GEWICHT <sup>2)</sup> WEIGHT <sup>2)</sup> KG
		min	max	A	C	L	L <sub>1</sub> + L <sub>2</sub>	E	G	F	g	h	e		
		MB 14	-	6	14	40	25	50	23	4	6,5	37	M5		
MB 24	-	10	24	52	36	56	26	4	7,5	41	M5	6	14	50	0,32
MB 28	-	12	28	66	43	84	40	4	19	46	M8	10	13	60	0,75
MB 32	-	14	32	76	50	84	40	4	18	48	M8	10	13	60	0,95
MB 38	-	18	38	83	58	84	40	4	18	48	M8	10	13	80	1,25
MB 42	-	20	42	92	65	88	42	4	19	50	M8	10	13	110	1,50
MB 48	-	20	48	100	68	104	50	4	27	50	M8	10	13	110	1,80
MB 65	-	25	65	140	96	144	70	4	36	72	M10	20	16	140	5,20
MB 80	-	30	80	175	124	186	90	6	46,5	93	M10	20	20	-	11,50

1) Fertigbohrungen nach ISO-Passung H7, Passfedernut nach DIN 6885, Blatt 1-JS9, konische Bohrungen siehe Seite 5.

2) Gewichte beziehen sich auf max. d, ohne Nut.

Bei der Kupplungsmontage ist darauf zu achten, dass das „E“-Maß exakt eingehalten wird. Sorgfältiges Ausrichten der Wellen erhöht die Lebensdauer der Kupplung.

1) Finish bores acc. to ISO-standard H7, keyway acc. to DIN 6885, sheet 1-JS9, taper bores see page 5.

2) Weights refer to materials aluminium / GG with d, max. without keyway. When mounting the coupling, dimension „E“ must be observed exactly. The stability of the coupling will be increased by careful alignment of the shafts.

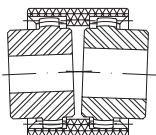

Winkelverlagerung /  
angular misalignment

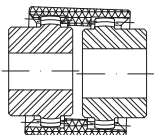

Radialverlagerung /  
radial misalignment

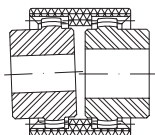

Radial- und Winkelverlagerung /  
radial and angular misalignment

## STAREX® FLEXIBLE COUPLINGS

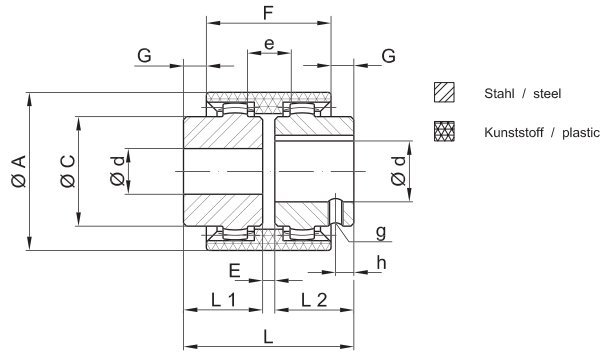

### PRODUCT DESCRIPTION

- Double cardanic curved tooth gear coupling
- Use in general mechanical engineering and hydraulics
- Maintenance-free by combination of materials plastic / steel
- Compensation of misalignment of shaft axial-radial-angular
- Axially pluggable - simple mounting
- Available with finish bore metric H7, taper bore and inch bore as well as toothed wheel work
- Base assortment available ex stock

### TECHNICAL DATA

### DREHMOMENT / DREHZAHL TORQUE / SPEED

TYP SIZE	DREHMOMENT TORQUE nm		MAX. DREHZAHL MAX. SPEED (1/MIN)	MAX. VERLAGERUNGEN MAX. MISALIGNMENT		ODER WINKLIG OR ANGULAR
	TKN	TK MAX.		AXIAL mm	RADIAL mm	
MB 14	10	20	14000	± 1	± 0,3	
MB 24	21	42	10500	± 1	± 0,4	
MB 28	45	90	8500	± 1	± 0,4	
MB 32	60	120	7500	± 1	± 0,4	
MB 38	81	162	6700	± 1	± 0,4	± 1° je Nabe per hub
MB 42	100	200	6000	± 1	± 0,4	
MB 48	142	285	5500	± 1	± 0,4	
MB 65	380	760	4000	± 1	± 0,6	
MB 80	700	1400	3100	± 1	± 0,7	

## BASISSORTIMENT ZYLINDRISCHE UND KONISCHE BOHRUNGEN

## BASIC PROGRAMME METRIC AND CONICAL (TAPER) BORES

STAREX® TYP SIZE	FERTIGBOHRUNGEN ISO-PASSUNG H7, NUT NACH DIN 6885, BLATT 1 FINISH BORES ACC. TO ISO-STANDARD H7, KEYWAY ACC. DIN 6885, SHEET 1																													
	8	9	10	11	12	14	15	16	18	19	20	22	24	25	28	30	32	35	38	40	42	45	48	50	55	60	65	70	75	80
14	•		•	•	•	•																								
24			•		•	•	•	•	•	•	•	•	•																	
28					•	•	•		•	•	•	•	•	•	•															
32											•	•	•	•	•		•													
38													•	•	•	•	•	•	•	•	•	•	•							
42												•	•	•	•	•	•	•	•	•	•	•	•	•	•	•	•	•	•	
48													•	•	•	•	•	•	•	•	•	•	•	•	•	•	•	•	•	
65																								•	•	•	•	•	•	•
80																													•	•

• Standard-Länge / Standard length      ■ Standard verlängert / Standard extended

STAREX® TYP SIZE	KEGEL 1:5 TAPER 1:5		KEGEL 1:8 TAPER 1:8					ZOLLBORUNGEN INCH BORES					
	A10	B17	N/1	N1d	N/2	N/2α	N/3	Ed	A	G	F	B <sub>s</sub>	K
14	•		•					•					
24	•	•	•	•	•	•	•		•	•	•		
28	•	•	•	•	•	•	•		•	•	•	•	
32							•						
38		•			•	•	•						•
42		•					•		•	•	•	•	•

## EINSATZTABELLE STAREX® FLEXIBLE FLANSCHKUPPLUNGEN STAREX®-FL-PA

## APPLICATION SCHEDULE STAREX® FLEXIBLE FLANGE COUPLINGS STAREX®-FL-PA

NENNGRÖSSE NOMINAL SIZE	STAREX®-NABE STAREX® HUB	MOTORHERSTELLER / TYPE MANUFACTURERS OF MOTORS / TYPE
6 1/2"-48	MB 42/48	Ford, Hatz, KHD, Kubota, Lister Petter, Lombardini, Perkins, Ruggerini, Slanzi, Teledyne
7 1/2"-48	MB 42/48	Ford, Hatz, Isuzu, KHD, Kubota, Lister Petter, Lombardini, Mitsubishi, Perkins, Yanmar
8"-48	MB 42/48	Cummins, Ford, Hatz, Isuzu, KHD, Lister Petter, Lombardini, Mitsubishi, Perkins, Peugeot, Slanzi, Teledyne
10"-48	MB 42/48	Cummins, Deere, Ford, Hatz, Hercules, Isuzu, KHD, Kubota, Lister Petter, Lombardini, Mitsubishi, Perkins, Slanzi, Toyota
10"-65	MB 65	Caterpillar, Cummins, Detroit Diesel, Daimler Benz, Ford, Hercules, Isuzu, John Deere, KHD, Lister Petter, Perkins, Slanzi
11 1/2"-65	MB 65	Cummins, Daimler Benz, Hercules, Hino, Isuzu, Ford, KHD, Lister Petter, Perkins, Valmet
11 1/2"-80	MB 80	Caterpillar, Cummins, Daimler Benz, Deere, Detroit Diesel, Hino, KHD, Perkins, Volvo
96 mm	MB 42/48	Hatz Z 788 / 789 / 790
125 mm	MB 42/48	KHD F1L208D, 210D, F2L511, F2L912, Lister Petter LP60, LP460, Lombardini 9LD560-2, Perkins 4.108, VW 026, 068
135 mm	MB 42/48	Kubota D 650 / 750 / 850 / 950 / 1402, Kubota V 1100 / 1200 / 1102 / 1302, Kubota Super 5 Serie
150 mm	MB 42/48	Kubota Super Mini Serie
152 mm	MB 42/48	Deutz F2L511, Hatz 673, 786, 786, Hatz E573, Perkins 4.108

## FLEXIBLE FLANSCHKUPPLUNGEN STAREX®-FL-PA

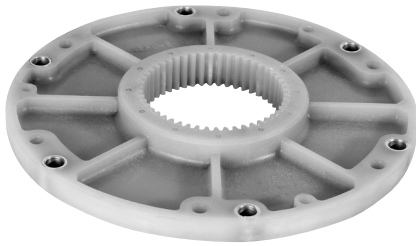

## FLEXIBLE FLANGE COUPLINGS STAREX®-FL-PA

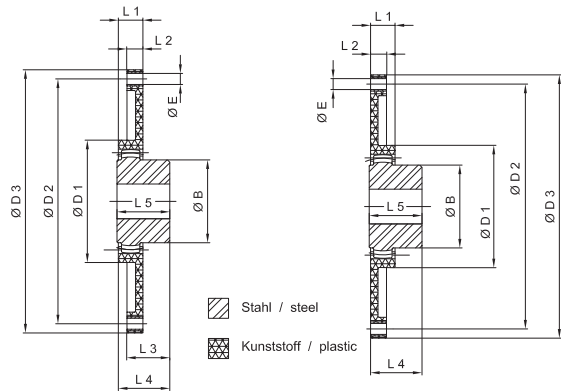

Montagebild 1  
Mounting instruction 1

Montagebild 2  
Mounting instruction 2

### PRODUKTBESCHREIBUNG

- Flanschkupplungen für den Anbau an Verbrennungsmotoren und Hydraulikpumpen
- Einsatz für alle hydrostatischen Antriebe von Baumaschinen, Erntemaschinen usw.
- Hohe Drehsteifigkeit - resonanzfreier Betrieb
- Wartungsfrei durch Werkstoffpaarung Kunststoff / Stahl
- Kunststoff-Flansch verfügt über hohe mechanische Festigkeit und Wärmeformstabilität (+130 °C)
- Extrem kurzer Einbau
- Einfache Montage durch axiales Zusammenführen

### PRODUCT DESCRIPTION

- Flange couplings for assembly to combustion engines and hydraulic pumps
- Use for all hydrostatic drives of machines for structural engineering, harvesters etc.
- High torsional rigidity - operation without resonance
- Maintenance-free by combination of materials plastic / steel
- Plastic flange with high mechanical strength and temperature dimensional stability (+130 °C)
- Extremely short assembly
- Simple mounting by axial fitting

### SAE-FLANSCHEN SAE FLANGES

TYP SIZE	LOCH- KREIS FIXING Ø	AUSSEN EXTERNAL Ø	BOHRUNGS Ø / ANZAHL BORE Ø / NUMBERS	DREH- MOMENT TORQUE Nm	
				NENN	MAX.
6 1/2"-48	200,02	215,90	9 (6x)	237	599
7 1/2"-48	222,25	241,30	9 (8x)	237	599
8"-48	244,47	263,52	11 (6x)	237	599
10"-48	295,27	314,32	11 (8x)	237	599
10"-65	295,27	314,32	11 (8x)	644	1605
11 1/2"-65	333,37	352,42	11 (8x)	644	1605
11 1/2"-80	333,37	352,42	11 (8x)	1198	3006

### METRISCHE-FLANSCHEN METRIC FLANGES

TYP SIZE	LOCH- KREIS FIXING Ø	AUSSEN EXTERNAL Ø	BOHRUNGS Ø / ANZAHL BORE Ø / NUMBERS
96-48	50	96	9 (4x)
125-48	100	125	9 (3x)
135-48	100	135	9 (3x)
130-48	105	130	11 (4x)
150-48	130	150	9 (5x)
152-48	122	152	12 (3x)
152-48	125	152	12 (3x)

### NABENABMESSUNG FÜR SAE-FLANSCHEN

TYP SIZE	FERTIGBOHRUNG FINISH BORE		ABMESSUNGEN DIMENSIONS mm							VERL. NABEN EXTENDED HUBS mm, L <sub>1</sub> MAX.	NENNMASS NACH SAE (D) NOMINAL SIZE ACC. TO SAE (D)				
	MIN.	MAX.	B	D <sub>1</sub>	L <sub>5</sub>	L <sub>3</sub>	L <sub>4</sub>	L <sub>1</sub>	L <sub>2</sub>		6 1/2"	7 1/2"	8"	10"	11 1/2"
MB 42	20	42	65	100	42	33	40	20	13	110	x	x	x	x	-
MB 48	20	48	68	100	50	41	48	20	13	110	x	x	x	x	-
MB 65	25	65	96	132	70	60	67	27	21	140	-	-	-	x	-
MB 65	25	65	96	170	70	60	67	31	21	140	-	-	-	-	x
MB 80	25	80	124	170	90	78	87	30	21	-	-	-	-	-	x

### HUB DIMENSIONS FOR SAE FLANGES

## BOHRAUSFÜHRUNGEN

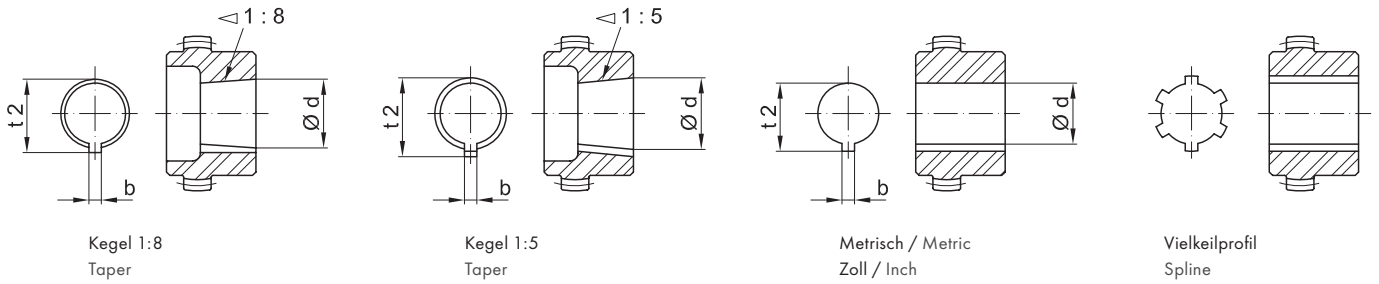

### KEGEL / TAPER 1:8

CODE CODE	BOHRUNGSANGABEN BORE DETAILS mm			
	$d\varnothing+0,05$	$b+0,05$	$t_2+0,1$	L
... N/1	9,7	2,4	10,7	17
... N/1c	11,6	3	12,9	16,5
... N/1e	13	2,4	13,8	21
... N/1d	14	3	15,5	17,5
... N/1b	14,3	3,2	15,7	19,5
... N/2	17,2	3,2	18,3	24
... N/2a	17,2	4	19,0	24
... N/2b	17,2	3	18,4	24
... N/3	22	4	23,5	28
... N/4	25,4	4,78	27,8	36
... N/4b	25,4	5	28,2	36
... N/4a	27	4,78	28,8	32,5
... N/4g	28,45	6	29,3	38,5
... N/5	33	6,35	35,5	44
... N/5a	33	7	35,5	44
... N/6	43,05	7,95	46,5	51
... N/6a	41,15	8	44,2	42,5

### KEGEL / TAPER 1:5

CODE CODE	BOHRUNGSANGABEN BORE DETAILS mm			
	$d\varnothing+0,05$	$b$ js 9	$t_2+0,1$	l
... A 10	9,85	2	10,85	11,5
... B 17	16,85	3	18,65	18,5
... C 20	19,85	4	22,05	21,5
... Cs 22	21,95	3	23,75	21,5
... D 25	24,85	5	27,75	26,5
... E 30	29,85	6	32,45	31,5
... F 35	34,85	6	37,45	36,5
... G 40	39,85	6	42,45	41,5

Vor den Code ist die jeweilige Kupplungsgröße zu setzen: z.B. MB 28 N/2a.

Für Profile nach DIN und SAE sowie Zollbohrungen bitte separate Liste anfordern.

The size of coupling should be inserted before the code: e.g. MB 28 N/2a.

For splines acc. to DIN and SAE as well as for inch bores please ask for our separate list.

## BORE CODES

### ZOLLBOHRUNGEN / INCH BORES

CODE CODE	METRISCH METRIC mm			ZOLL INCH	
	$d\varnothing$	$b+0,05$	$t_2+0,1$	$d\varnothing$	b
DNB	11,11 M7	2,4	12,5	$\frac{7}{16}$	$\frac{3}{32}$
V	11,11 + 0,03	3,2	12,6	$\frac{7}{16}$	$\frac{1}{8}$
Ta	12,7 + 0,03	3,2	14,3	$\frac{1}{2}$	$\frac{1}{8}$
E	15,87 + 0,03	3,2	17,5	$\frac{5}{8}$	$\frac{1}{8}$
Ed	15,87 + 0,03	4,75	18,1	$\frac{5}{8}$	$\frac{5}{16}$
ES	15,88 + 0,03	4,0	17,7	$\frac{5}{8}$	$\frac{5}{32}$
Ad	19,02 + 0,03	3,2	20,7	$\frac{3}{4}$	$\frac{1}{8}$
A	19,05 + 0,03	4,78	21,3	$\frac{3}{4}$	$\frac{3}{16}$
Gs	22,22 + 0,03	4,78	24,4	$\frac{7}{8}$	$\frac{3}{16}$
G	22,22 + 0,03	4,75	24,7	$\frac{7}{8}$	$\frac{3}{16}$
F	22,22 + 0,03	6,35	25,2	$\frac{7}{8}$	$\frac{1}{4}$
B	25,37 + 0,03	4,78	27,8	1	$\frac{3}{16}$
Bs	25,38 + 0,03	6,37	28,3	1	$\frac{1}{4}$
HS	25,4 + 0,03	6,35	28,7	1	$\frac{1}{4}$
SB	28,58 + 0,03	6,35	31,5	$1\frac{1}{8}$	$\frac{1}{4}$
Sd	28,58 + 0,03	7,93	32,1	$1\frac{1}{8}$	$\frac{5}{16}$
Js	31,75 + 0,03	6,35	34,6	$1\frac{1}{4}$	$\frac{1}{4}$
J	31,75 + 0,03	7,93	34,4	$1\frac{1}{4}$	$\frac{5}{16}$
K	31,75 M7	7,93	35,5	$1\frac{1}{4}$	$\frac{5}{16}$
KS	31,75 + 0,03	7,93	36,6	$1\frac{1}{4}$	$\frac{5}{16}$
M	34,92 + 0,03	7,93	38,6	$1\frac{3}{8}$	$\frac{5}{16}$
CB	36,5 + 0,03	9,55	38,6	$1\frac{7}{16}$	$\frac{3}{8}$
C	38,07 + 0,03	9,55	42,5	$1\frac{1}{2}$	$\frac{3}{8}$
N	41,25 + 0,03	9,55	45,6	$1\frac{5}{8}$	$\frac{3}{8}$
L	44,45 K7	11,11	49,4	$1\frac{3}{4}$	$\frac{7}{16}$
NM	47,625 + 0,03	12,73	53,5	$1\frac{7}{8}$	$\frac{1}{2}$
DS	50,77 + 0,03	12,73	56,4	2	$\frac{1}{2}$
P	53,95 + 0,03	12,73	59,6	$2\frac{1}{8}$	$\frac{1}{2}$
U	57,1 + 0,03	12,73	62,9	$2\frac{1}{4}$	$\frac{1}{2}$
UB	60,3 + 0,03	15,87	67,6	$2\frac{3}{8}$	$\frac{5}{8}$
W	69,85 M7	15,875	77,3	$2\frac{3}{4}$	$\frac{5}{8}$
WA	73,0 + 0,03	19,05	81,7	$2\frac{7}{8}$	$\frac{3}{4}$
WD	85,725 M7	22,225	95,8	$3\frac{3}{8}$	$\frac{7}{8}$
WE	88,9 + 0,03	22,225	98,6	$3\frac{5}{8}$	$\frac{7}{8}$
WF	92,075 M7	22,225	101,9	$3\frac{5}{8}$	$\frac{7}{8}$

HBE behält sich das Recht vor, jederzeit technische Änderungen durchzuführen.  
HBE reserves the right to modify technical data at any time.